

DK790V-XEC

4½ DIGIT LOOP LCD DPM INSTALLATION SHEET

PANEL CUTOUT & DIMENSIONS

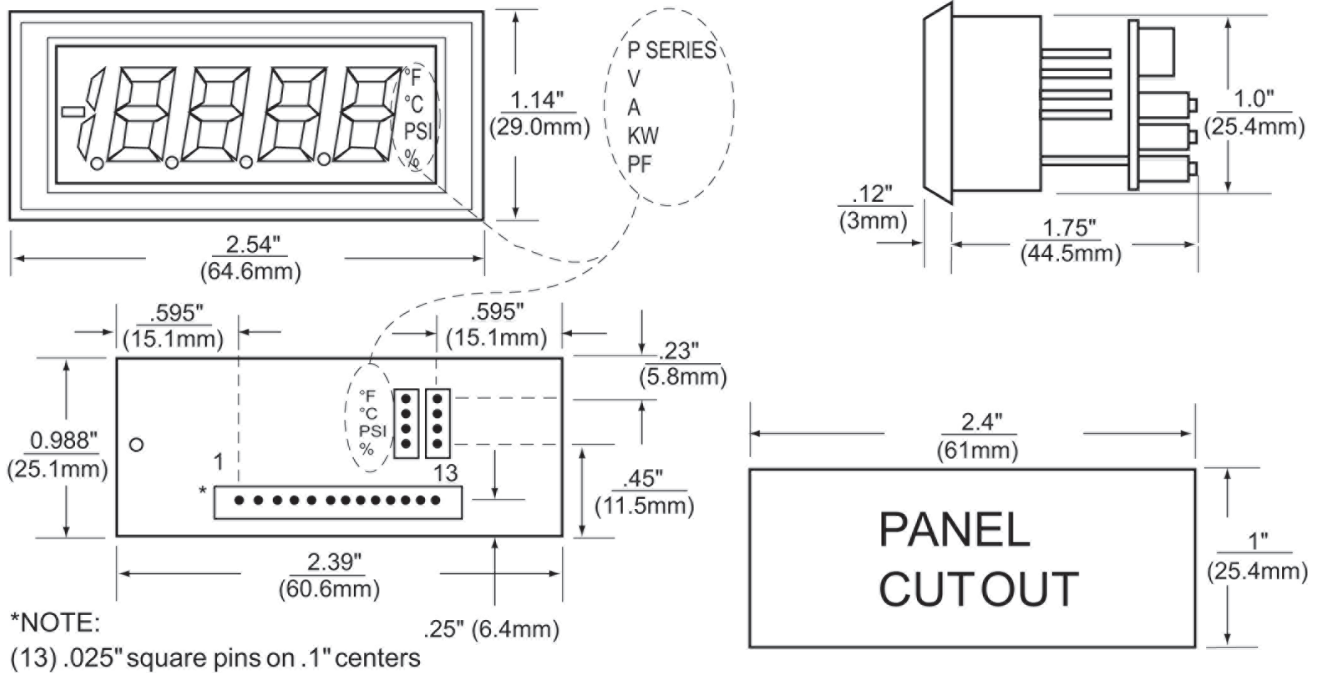

JUMPER SELECTION AND WIRING

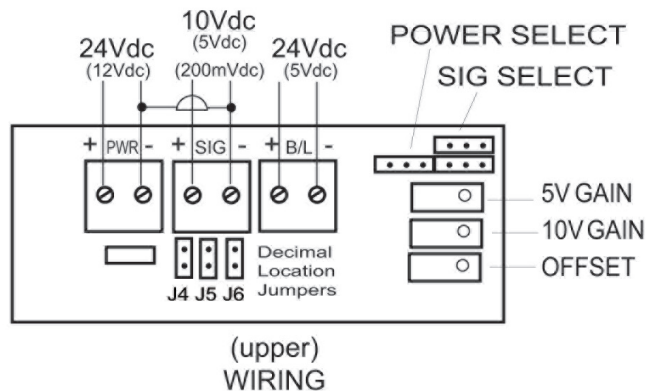

Decimal Point Selection

1. Locate jumpers J4 through J6 in the middle of the circuit board unit.
2. Jumper the appropriate decimal location as follows:
 - J4 - 000.0
 - J5 - 00.00
 - J6 - 0.000
 - None - 0000